

Effects of Various Preparation and Polymerization Procedures on the Isospecific Nature of TiCl_3 -Based Polypropylene Catalysts

ATM Kamrul Hasan, Boping Liu, Minoru Terano (✉)

School of Materials Science, Japan Advanced Institute of Science and Technology,
1-1 Asahidai, Nomishi, Ishikawa 923-1292, Japan

Email: terano@jaist.ac.jp; Fax: 81 761 51 1625

Received: 2 March 2005 / Revised version: 30 April 2005 / Accepted: 11 May 2005
Published online: 25 May 2005 – © Springer-Verlag 2005

Summary

As one of a series approaches in using two-component and three-component donor-free Ziegler-Natta catalysts, in this preliminary work, the effects of various preparation and polymerization conditions including catalyst preparation by wet- or dry- grinding, the type of cocatalyst, with or without pretreatment of catalyst by cocatalyst before polymerization, Al/Ti molar ratio and polymerization temperature, etc., on the isospecific nature of active sites of the TiCl_3 catalyst were studied through a systematic characterization of the PPs by a combination of GPC, ^{13}C -NMR with TREF method. It was demonstrated that the types of Al-alkyl cocatalysts play the most dominant role in determination of isospecificity of activate sites and its distribution. A plausible mechanism (Scheme 1) regarding the formation of isospecific active sites with different stability in terms of Ti-Al bimetallic complexing depending on the type of cocatalyst had been proposed. Except the catalyst grinding method, other factors eg., pretreatment, temperature, and Al/Ti molar ratio, etc. did not show obvious effects on the isospecific nature of active sites.

Introduction

Ziegler-Natta catalyst is one of the most important discoveries in the chemistry field in the 20th century with respect to its great contributions for commercial production and application of various new polyolefin materials as well as for academic developments in the fields of coordination, organometal and polymer chemistry [1, 2]. Great research efforts from both industrial and academic circles have been successively put into this most important industrial catalyst for more than 50 years up to now. One of the most important breakthroughs in this field since the original discovery is the finding of MgCl_2 as supporting materials for Ziegler-Natta catalyst in late 1960's [3], which can only produce polypropylene with poor isotacticity. Thereafter within the past two decades, PP product with ultra-high isotacticity has been developed based on successful innovation of electron donors for several generations including monoester, diester, alkoxy silane, diether and succinates in the

industrial field [3]. In spite of the great industrial success and half centuries of research efforts since 1953, many aspects concerning the active sites and polymerization mechanism in Ziegler-Natta catalysis still remained ambiguous and controversial [4]. Regarding polypropylene catalyst, although various types of models concerning the stereospecific active sites had been proposed up to now based on drastic amount of experimental and theoretical approaches [5~10], the real origin of isospecificity of active sites and specific stereochemical role of various catalytic components including electron donor are still open for discussion. As it has been reported in the literature, the stereospecific nature of active sites on heterogeneous Ziegler-Natta catalyst could be significantly affected not only by electron donors [11, 12] but also by various other factors including other catalytic components like the types of titanium compounds, Al-alkyl cocatalysts and Mg-compounds [5, 7~9, 13~15], as well as various catalyst preparation and polymerization conditions [3], whereas the specific stereospecific role of each factor has not been completely clarified yet.

Within the last decades, we have made much deeper understanding on the stereospecific role of electron donors on the industrial MgCl_2 -supported Ziegler-Natta catalysts through combination of stopped-flow technique with temperature rising elution fractionation (TREF) analysis of the PP produced [16~19]. More recently, a donor-free $\text{TiCl}_4/\text{MgCl}_2$ Ziegler-Natta catalyst was investigated by the same methods in order to further clarify the stereospecific roles of MgCl_2 , titanium chloride and Al-alkyl cocatalyst [20]. A modified three-sites model [20~22] in terms of sites transformation has been speculated based on the three-sites model proposed by Busico et al. [10]. Further simplification of the three-component ($\text{TiCl}_4/\text{MgCl}_2/\text{Al-Alkyl}$) donor-free Ziegler-Natta catalyst into a two-component (TiCl_3 or $\text{TiCl}_4/\text{Al-Alkyl}$) donor-free catalyst can be expected to favor further development in this basic topic of Ziegler-Natta stereochemistry. The ultimate long-term objective is to completely elucidate the molecular origins of the stereospecificity of active sites with respect to various of catalytic factors in heterogeneous Ziegler-Natta catalysis and finally to realize the state-of-the-art design of new catalysts with ultimate performance. In this preliminary work, the effects of various preparation and polymerization conditions including catalyst preparation by wet- or dry- grinding, the type of cocatalyst, with or without pretreatment of the catalyst by cocatalyst before polymerization, Al/Ti molar ratio and polymerization temperature, etc., on the isospecific nature of active sites was systematically studied through a systematic characterization of the PPs by a combination of GPC, ^{13}C -NMR with TREF method.

Experimental

Materials

Research grade propylene donated by Chisso Corp. and anhydrous TAC-100 ($\text{TiCl}_3 \cdot 1/3\text{AlCl}_3$) were kindly supplied by Toho Titanium Co., Ltd. Heptane and toluene purchased from Wako Pure Chemical Industries, Ltd. were purified by passing slowly through a column containing molecular sieves 13X under continuous nitrogen flow. Pure nitrogen was purchased from Uno Sanso Corporation. Triethylaluminum (TEA) and diethylaluminumchloride (DEAC) cocatalysts purchased from Tosho Akzo Corp. was used without further purification as a toluene solution.

Catalyst preparation and characterization

The catalyst sample (36g TAC-100 $\text{TiCl}_3 \cdot 1/3 \text{AlCl}_3$) was treated with 200 ml heptane for the wet ground (WG) catalyst or without heptane for the dry ground (DG) catalyst by ball milling method using a vibratory machine. The grinding of each sample was carried out in a 1.2 L stainless steel pot containing 55 stainless steel balls, 25 mm in diameter each and ground for 30h at room temperature under nitrogen atmosphere. The Ti contents of catalysts were determined by redox titration method. Microtrac-FSA GP-5-2-3H072 (Nikkiso Co., Ltd.) particle size analyzer was used for the measurement of particle size and particle size distribution of both catalysts (Fig. 1).

Propylene polymerization and characterization of PPs

Slurry propylene polymerization experiments were conducted in a three-necked 300 ml round-bottomed flask reactors equipped with magnetic stirring chips under nitrogen atmosphere maintaining the conditions as: 2mmol Ti, and Al/Ti molar ratio 3 or 10, total volume 150 ml, pretreatment time 0 or 10 min, temperature 40 or 60°C, propylene pressure 0.5 bar, and polymerization time 5~30 min. PPs obtained from this experiment were successively characterized by ^{13}C NMR (GEOL GSX-270) for isotacticity as mesopentad fractions, temperature rising elution fractionation (TREF, Senshu SSC-7300) for the isotacticity distribution in terms of isospecificity distribution of active sites, and GPC (Senshu SSC-7100) for the molecular weight and molecular weight distribution.

Results and discussion

In this work, two kinds of catalysts with respect to preparation conditions were prepared from the industrial TAC-100 ($\text{TiCl}_3 \cdot 1/3 \text{AlCl}_3$) catalyst sample by WG or DG method. The particle size and particle size distribution for the WG and DG catalysts are shown in Fig.1. As it can be seen, WG catalyst shows a very narrow uni-modal particle size distribution ranging from 0.8 μm to 8 μm with an average particle size of 3 μm . On the other hand, DG catalyst shows a very wide multi-modal particle size distribution ranging from 0.8 μm to >100 μm with an average particle size of 18 μm . These results indicate that the existence (for WG) or absence (for DG) of heptane as a solvent during ball-milling may significantly change the fragmentation mode of the $\text{TiCl}_3 \cdot 1/3 \text{AlCl}_3$ catalyst sample and thus also change the particle size and particle size

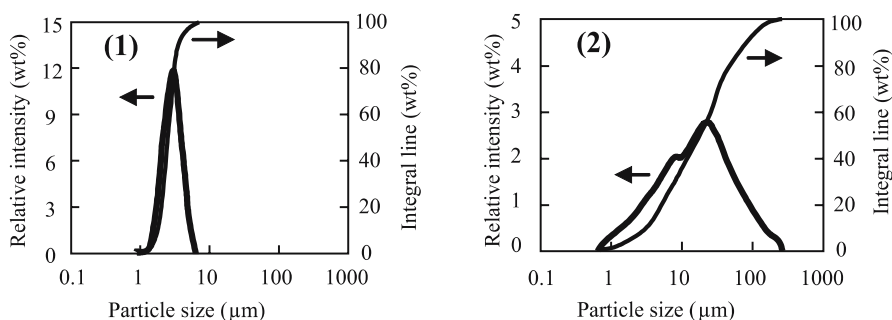

Figure 1. Particle size distribution and an integral curves of donor-free TiCl_3 catalyst (1) WG and (2) DG.

distribution as well as the surface area of the two catalysts. Higher surface area could be expected for the WG catalyst. The comparison between the polymerization behaviors of these two catalysts will be discussed in detail later. For the subsequent investigation on the isospecific nature of the WG and DG catalysts, an ideal method is to combine the stopped-flow technique with TREF and NMR analysis of the PP produced [16~19], in which direct information corresponding to the relationship between isotacticity of each polymer chain and the isospecificity of the each relevant active site can be obtained [4]. However, the polymerization activity (especially in the initial stage) of $\text{TiCl}_3 \cdot 1/3\text{AlCl}_3$ catalyst is too low, compared with the MgCl_2 -supported Ziegler-Natta catalysts, to get enough polymer within ~0.2s for further characterization.

Therefore, usual long-term slurry polymerization method was applied in this study in order to get enough PP for the subsequent GPC, NMR and TREF characterizations. Regarding the effects of polymerization conditions on the isospecific nature of the WG and DG catalysts, the following factors including the type of Al-alkyl cocatalyst (TEA and DEAC), with or without pretreatment of the catalyst by cocatalyst before polymerization (pretreatment time: 0 and 10 min), Al/Ti molar ratio (3 and 10), polymerization temperature (40°C and 60°C) and polymerization time (5, 10 and 30 min) were considered for this study. The dependences of polymer yield, isotacticity of PPs obtained from WG and DG catalysts on the type of cocatalyst (TEA and DEAC), with or without 10 min's pretreatment of the catalyst by cocatalyst before polymerization (un-pretreated (UP) and pretreated (PT)) with a polymerization time for 5, 10 and 30 min are shown in Table 1, Table 2, and Table 3, respectively. The average polymerization activity within 30 min, molecular weight (MW) and molecular weight distribution (MWD) for the PPs produced with a polymerization time of 30 min are also shown in Table 3.

It can be seen that WG catalysts always show much higher polymer yield for all polymerization runs (5, 10, and 30 min) and thus much higher average polymerization activity than DG catalysts irrespective of the type of cocatalyst and the existence of pretreatment. This difference in the polymerization activity obtained from WG and DG catalysts in any conditions may be rationalized in terms of the catalyst preparation method as follows. The PSD results (shown in Figure 1) have demonstrated that WG method produced very fine-grain particles with regular size but DG method produced course particles with irregular size indicating the higher surface area for the WG catalyst.

According to Mejzlík and co-authors [23], the grinding of TiCl_3 in hydrocarbon medium (WG) not only increases the specific surface, but also causes a basic change in the reactivity of the TiCl_3 surface as well. The reason for the better performance of the WG catalyst may be that during WG grinding the solvent can be diffused at the interface of the crystalline catalyst, for which heat and mass transfer can be easily occurred by the applying of weak shear force and hence, solid catalyst is thought to be disintegrated layer-wise keeping the small particles with good morphology [23]. On the other hand, for DG method, solid catalyst in the absence of solvent is disintegrated not only parallel to lay surface but also perpendicularly to the plane of crystalline layer due to a strong shear force, for which after grinding, catalyst particles become irregular size with the formation of rough surface and defects. Boor [24] had

Table 1. The relationship of yield and isotacticity of PPs obtained in slurry propylene polymerization with the donor-free TiCl_3 catalyst. The polymerization was conducted at polymerization time = 5 min, Temp. = 40°C , Ti = 2 mmol, Al/Ti molar ratio = 3 conditions.

Catalyst system	Yield (g-PP/g-Ti)	mmmm ^{a)} (mol%)	mmmr ^{a)} (mol%)	mrrm ^{a)} (mol%)	mrrm ^{a)} (mol%)
WG/TEA/UP ^{b)}	8.1	70.7	8.4	10.9	10.0
WG/TEA/PT ^{c)}	7.6	73.2	7.7	10.2	8.7
DG/TEA/UP ^{b)}	5.7	63.9	10.5	13.9	11.7
DG/TEA/PT ^{c)}	4.7	68.4	8.8	12.2	10.7
WG/DEAC/UP ^{b)}	0.9	92.7	4.8	2.3	0.2
WG/DEAC/PT ^{c)}	0.7	94.6	3.5	1.3	0.5
DG/DEAC/UP ^{b)}	0.2	87.7	5.4	4.1	2.9
DG/DEAC/PT ^{c)}	0.1	88.7	4.0	3.8	3.5

a) obtained from ^{13}C NMR

b) “UP” indicates the catalyst was unpretreated before polymerization

c) “PT” indicates the catalyst was pretreated by the cocatalyst for 10 min before polymerization

Table 2. The relationship of yield and isotacticity of PPs obtained in slurry propylene polymerization with the donor-free TiCl_3 catalyst. The polymerization was conducted at polymerization time = 10 min, Temp. = 40°C , Ti = 2 mmol, Al/Ti molar ratio = 3 conditions.

Catalyst system	Yield (g-PP/g-Ti)	mmmm ^{a)} (mol%)	mmmr ^{a)} (mol%)	mrrm ^{a)} (mol%)	mrrm ^{a)} (mol%)
WG/TEA/UP ^{b)}	12.9	64.6	11.4	13.0	10.9
WG/TEA/PT ^{c)}	12.6	70.8	8.0	11.1	10.1
DG/TEA/UP ^{b)}	9.6	62.8	9.9	14.9	12.5
DG/TEA/PT ^{c)}	9.1	65.3	10.3	13.5	10.9
WG/DEAC/UP ^{b)}	2.3	90.2	4.5	4.0	1.2
WG/DEAC/PT ^{c)}	2.1	93.9	4.0	1.7	0.5
DG/DEAC/UP ^{b)}	0.3	81.8	6.3	7.2	4.7
DG/DEAC/PT ^{c)}	0.2	79.6	7.6	7.9	4.9

a) obtained from ^{13}C NMR

b) “UP” indicates the catalyst was unpretreated before polymerization

c) “PT” indicates the catalyst was pretreated by the cocatalyst for 10 min before polymerization

postulated that the active polymerization sites involve with the various kinds of chlorine vacancies or defects on the surface of the TiCl_3 crystal, which are responsible for the different reactivities and stereoregulating abilities. One other reason for multimodal broad peaks of DG catalyst is that some primary particles may be aggregated with the formation of catalyst cluster during grinding, which lowered the surface area and the result is the change of the overall PSD. According to the literature [25-28], the most striking effect of dry grinding (DG) are the drastic crystallographic changes induced by the sufficiently strong shear forces to cause sliding at the metal-free interfaces of the Cl-Ti-Cl double layer. This leads to a disorder in the stacking of the double layers, which becomes essentially random after prolonged intense dry grinding. By contrast, intense wet milling of the same procedures produced only minor crystallographic changes. Thus, much more active species are exposed on the WG catalyst surface, which is responsible for higher activity and the opposite trend can be considered for DG catalyst [29~32]. Another important aspect demonstrated in this work is that the types of cocatalyst play the most fundamental role in determination of the catalytic activity for both WG and DG catalysts. In this regard, it was observed that TEA as a cocatalyst always shows much higher activity with all catalyst systems compared with that of DEAC.

Table 3. The relationship of yield, activity, number average molecular weight (Mn), molecular weight distribution (Mw/Mn), and isotacticity of PPs obtained in slurry propylene polymerization with the donor-free TiCl_3 catalyst. The polymerization was conducted at polymerization time = 30 min, Temp. = 40°C , Ti = 2 mmol, Al/Ti molar ratio = 3 conditions.

Catalyst system	Yield (g-PP/g-Ti)	Activity (g-PP/g-Ti·h)	Mn ^{a)}	Mw/Mn ^{a)}	mmmm ^{b)} (mol%)	mmmr ^{b)} (mol%)	mrrm ^{b)} (mol%)	mrrm ^{b)} (mol%)
WG/TEA/UP ^{c)}	53.6	107.2	18000	17.6	71.7	9.0	10.6	8.7
WG/TEA/PT ^{d)}	43.2	86.4	18300	14.0	72.1	8.3	10.3	9.3
DG/TEA/UP ^{c)}	16.0	32.0	18700	15.5	62.6	11.0	14.7	11.7
DG/TEA/PT ^{d)}	14.9	29.8	19000	12.7	65.2	11.0	12.6	11.2
WG/DEAC/UP ^{c)}	7.3	14.6	41800	15.9	92.2	4.6	2.6	0.6
WG/DEAC/PT ^{d)}	7.2	14.4	51000	13.5	93.6	4.7	1.9	0.0
DG/DEAC/UP ^{c)}	5.6	11.2	30000	17.1	82.7	4.4	4.9	8.0
DG/DEAC/PT ^{d)}	5.1	10.2	40200	13.8	87.5	7.2	3.1	2.2

^{a)} obtained from GPC

^{b)} obtained from ^{13}C NMR

^{c)} "UP" indicates the catalyst was unpretreated before polymerization

^{d)} "PT" indicates the catalyst was pretreated by the cocatalyst for 10 min before polymerization

It is generally accepted [20, 33] that the formation of active sites is accomplished through the reduction and alkylation of surface titanium species by the interaction of the catalyst with cocatalyst. In the presence of TEA, titanium trichlorides are immediately alkylated with the formation of more active sites for polymerization. In contrast, DEAC interacts with the titanium species with the slow formation of less amount of active sites, which take part in the polymerization at slow rate. The DEAC-activated byproduct ($\text{C}_2\text{H}_5\text{AlCl}_2$) in the alkylation step plays an adverse role in the polymerization reaction, which can possibly be complexed to the active sites and poisons the catalytic activity.

It was demonstrated [34] that the addition of $\text{C}_2\text{H}_5\text{AlCl}_2$ in the catalyst system reduced the rate of polymerization reaction. Whereas, the pretreatment procedure of catalyst with cocatalyst before polymerization showed slightly lower yield in all polymerization runs in comparison to the unpretreated catalyst may be due to the deactivation through over-reduction of active Ti species for long period of interaction between catalyst active sites and cocatalyst or cocatalyst-activated byproduct in the absence of monomer. The influences of polymerization temperature (40°C and 60°C) and Al/Ti molar ratio (3 and 10) on the catalyst activity, MW and MWD of PPs as well as nature of isospecific active sites of the WG and DG catalysts using TEA or DEAC as a cocatalyst were studied and the results were illustrated in Table 4. As it can be seen, catalytic activity in presence of TEA decreased drastically with the increase of both polymerization temperature and Al/Ti molar ratio for all catalyst systems. The most likely explanation is that at higher polymerization temperature and Al/Ti ratio, there may have an explosion just after the interaction between catalyst and cocatalyst in the reactor resulting the formation of irregular particle size and shapes causes the reduction of catalytic activity. One other assumption can be cited here in supporting this result is that catalyst fragmentation can be occurred at higher temperature and Al/Ti molar ratio very rapidly for which heat and mass transfer can not be performed properly and in this situation polymer produced at the initial stage can be melted by overheating of the local area [35].

Table 4. The relationship of yield, activity, number average molecular weight (Mn), molecular weight distribution (Mw/Mn), and isotacticity of PPs obtained in slurry propylene polymerization with the donor-free TiCl_3 catalyst. The polymerization was conducted at polymerization time = 30 min, Temp. = 40, 60°C; Ti = 2 mmol, Al/Ti molar ratio = 3, 10 conditions.

Catalyst system	Yield (g-PP/g-Ti)	Activity (g-PP/g-Ti·h)	Mn ^{a)}	Mw/Mn ^{a)}	mmmm ^{b)} (mol%)	mmmr ^{b)} (mol%)	mrrm ^{b)} (mol%)	rrmm ^{b)} (mol%)
TEA/40 ^{c)} /3 ^{d)}	53.6	107.2	18000	17.6	71.7	9.0	10.6	8.7
TEA/40 ^{c)} /10 ^{d)}	28.0	56.0	21300	26.4	74.2	9.0	9.5	7.3
TEA/60 ^{c)} /3 ^{d)}	24.6	49.2	13800	35.2	67.3	10.2	12.1	10.3
DEAC/40 ^{c)} /3 ^{d)}	7.3	14.6	41800	15.9	92.2	4.6	2.6	0.6
DEAC/40 ^{c)} /10 ^{d)}	9.2	18.4	115300	9.5	89.6	6.6	2.5	1.4
DEAC/60 ^{c)} /3 ^{d)}	12.1	24.2	38900	10.7	88.6	7.0	3.0	1.4

^{a)} obtained from GPC

^{b)} obtained from NMR

^{c)} indicates polymerization temperature

^{d)} indicates Al/Ti molar ratio

This melt polymer can encapsulate the neighboring catalyst particle and prevent it from the chain propagation resulting the reduction of activity. A clearer evidence [35] in supporting to the above explanation can be illustrated that the morphology of the catalyst particle changes from the smooth surface structures towards the irregular shaped particles. But in the presence of DEAC, the explosion of catalyst particles after contact with cocatalyst is not so strong may be due to the weak activation power. The molecular weight (MW) and molecular weight distributions (MWD) of PPs obtained from TiCl_3 catalysts were determined through GPC analyses. The data and GPC spectra were shown in Table 3, Table 4 and Figure 2, Figure 3.

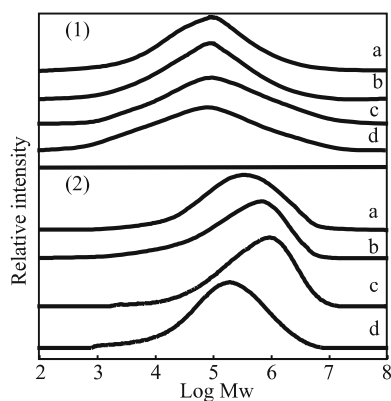

Figure 2. GPC curves of PPs produced with donor-free WG TiCl_3 catalyst for 30 min propylene polymerization. (1) TEA(a) 40°C, Al/Ti=3, UP, (b) 40°C, Al/Ti=3, PT, (c) 40°C, Al/Ti=10, UP, (d) 60°C, Al/Ti=3, UP and (2) DEAC (a) 40°C, Al/Ti=3, UP, (b) 40°C, Al/Ti=3, PT, (c) 40°C, Al/Ti=10, UP, (d) 60°C, Al/Ti=3, UP.

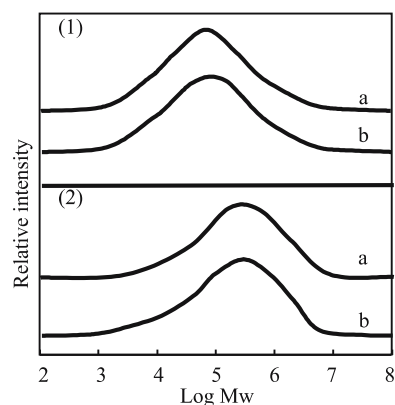

Figure 3. GPC curves of PPs produced with donor-free DG TiCl_3 catalyst for 30 min propylene polymerization. (1) TEA (a) 40°C, Al/Ti=3, UP, (b) 40°C, Al/Ti=3, PT and (2) DEAC (a) 40°C, Al/Ti=3, UP, (b) 40°C, Al/Ti=3, PT.

As it can be seen, the TiCl_3 catalysts produced PPs with broad MWD ranging from 9.5 to 35.2. It has been well established [29] that TiCl_3 catalyst contains multiple states of active sites, which usually produce polymer with broad molecular weight distributions. It was demonstrated that the number average MW was greatly affected by the types of cocatalyst. The PPs produced with TEA as a cocatalyst show much lower value of number average MW compared with those using DEAC as a cocatalyst. The replacement of TEA as a cocatalyst with DEAC has been known for a long time as depressing the activity and resulting in an increase of MW of polymer due to lower chain transfer ability [36]. Another point can be observed in Table 3 is that pretreated (PT) TiCl_3 catalysts produce PPs with slightly higher number average MW and slightly narrower MWD than the PPs obtained from unpretreated (UP) TiCl_3 catalysts. This can be rationalized by the fact that pretreatment of catalyst using cocatalyst usually deactivates those aspecific active sites and transfer some active sites with lower isospecificity into highly isospecific active sites [20-22]. The number average MW and MWD of PPs produced with the WG catalyst were also changed at higher polymerization temperature and Al/Ti molar ratio. As shown in Table 4 and Figure 3, the number average MW was increased at higher Al/Ti molar ratio but decreased at higher temperature for both TEA and DEAC cocatalysts. It is supposed that the higher temperature will favor the chain transfer reactions with usually much higher activation energies much more than the chain propagation reaction with much lower activation energy and thus to lower the degree of polymerization at elevated temperatures [37, 38]. On the other hand, MWD of PPs obtained in the presence of TEA was increased at elevated Al/Ti molar ratio and polymerization temperature, while, a reversed tendency was observed for WG catalysts using DEAC as cocatalyst.

In the previous sections, the general polymerization results regarding polymer yield, activity, MW, MWD using the WG and DG catalysts with respect to type of cocatalyst, pretreatment, Al/Ti molar ratios and polymerization temperature had been discussed. The later sections will be focused on a detailed interpretation of those ^{13}C NMR and TREF results relating to the isospecific nature of active sites on the TiCl_3 catalysts. The ^{13}C NMR results of PPs produced with the WG and DG TiCl_3 catalyst using TEA or DEAC as a cocatalyst under different conditions are listed in the Table 1 ~ Table 4. As it can be seen, the average isospecificity of active sites using DEAC as a cocatalyst is usually much higher than that using TEA as a cocatalyst. In general, the mesopentad fraction of PPs obtained from DEAC is usually ca. 20% higher than that obtained from TEA. Correspondingly, the number of racemic mis-insertions of propylene in PPs obtained from DEAC is much lower than that obtained from TEA. The second most important factor for determination of the average isospecificity of active sites for TiCl_3 catalysts was found to be the catalyst preparation condition in terms of either WG or DG method. The average isospecificity of active sites of WG catalyst is usually much higher than that of the DG catalyst. Generally speaking, the mesopentad fraction of PPs obtained from WG catalysts is usually ca. 10% higher than that obtained from DG catalysts. Correspondingly, the number of racemic mis-insertions of propylene in PPs obtained from WG catalyst is lower than that obtained from DG catalysts. It can also be observed that pretreatment of the catalyst with cocatalyst slightly increases the average isospecificity of active sites for both WG and DG catalysts. As mentioned previously, this can be due to the fact that pretreatment of catalyst using cocatalyst usually deactivates some aspecific active sites and transfer some active sites with lower isospecificity into highly isospecific

active sites [20-22]. It was also made clear that no obvious dependence of average isospecificity of active sites on the polymerization time (from 5 min to 30 min) could be found. It is assumed that the isospecific nature of active sites on the surface of catalyst particles formed by interaction with cocatalyst is not changed during the polymerization time. That's why only the PPs produced after 30 min polymerization were analyzed by TREF method. The increase of polymerization temperature and Al/Ti molar ratio has not shown remarkable effects on the isospecific nature of active sites (Table 4). It was only observed that the isotacticity has slightly decreased with increasing polymerization temperature. This slight decrease in isospecificity could be due to the effects of random monomer insertion at higher temperature [39].

In order to understand the isospecific nature in terms of isospecificity distribution of active sites on donor-free TiCl_3 catalysts, the isotacticity distribution of PPs produced with these catalyst systems after 30min polymerization were characterized by means of TREF method and the TREF curves are shown in Figure 4 and Figure 5. Accordingly, PP chains eluted from 20°C to 140°C for each TREF measurement can be divided into four different temperature ranges namely $\sim 20^\circ\text{C}$, $20\sim 100^\circ\text{C}$, $100\sim 110^\circ\text{C}$ and $110\sim 140^\circ\text{C}$, which are thought to be corresponding to four kinds of active sites with different isospecificity defined as aspecific active sites (AS-sites, creating the $\sim 20^\circ\text{C}$ fraction), semi-isospecific active sites (IS_1 -sites, producing the $20\sim 100^\circ\text{C}$ fraction), the second highest isospecific active sites (IS_2 -sites, making the $100\sim 110^\circ\text{C}$ fraction) and the highest isospecific active sites (IS_3 -sites, generating the $110\sim 140^\circ\text{C}$ fraction), respectively [20, 21]. As shown in Figure 4 and Figure 5, all the catalyst systems combined with TEA cocatalyst show the highest amount of aspecific active sites (AS-sites) and the second highest amount of the highest isospecific active sites (IS_3 -sites) is much less than that of the AS-sites. On the other hand, all the

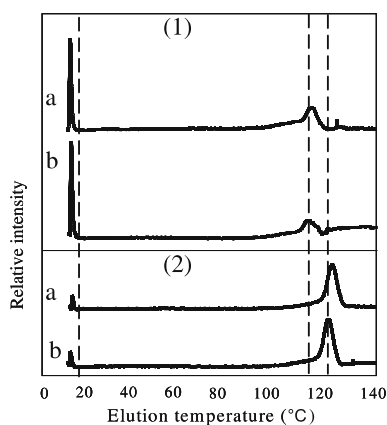

Figure 4. Temperature rising elution fractionation diagrams of PPs produced with donor-free DG TiCl_3 catalyst for 30 min propylene polymerization. (1) TEA (a) 40°C , Al/Ti=3, UP, (b) 40°C , Al/Ti=3, PT and (2) DEAC (a) 40°C , Al/Ti=3, UP, (b) 40°C , Al/Ti=3, PT.

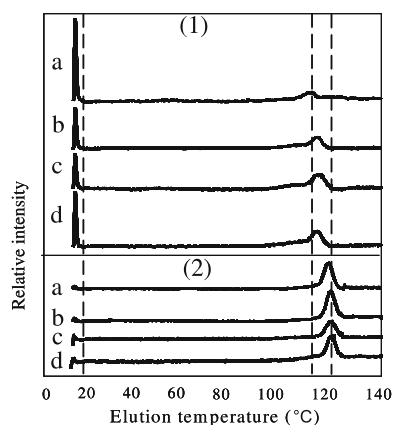
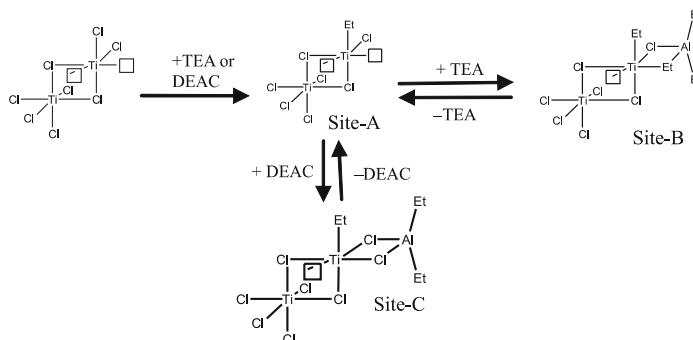

Figure 5. Temperature rising elution fractionation diagrams of PPs produced with donor-free WG TiCl_3 catalyst for 30 min propylene polymerization. (1) TEA (a) 40°C , Al/Ti=3, UP, (b) 40°C , Al/Ti=3, PT, (c) 40°C , Al/Ti=10, UP, (d) 60°C , Al/Ti=3, UP and (2) DEAC (a) 40°C , Al/Ti=3, UP, (b) 40°C , Al/Ti=3, PT, (c) 40°C , Al/Ti=10, UP, (d) 60°C , Al/Ti=3, UP.

catalyst systems combined with DEAC cocatalyst dominantly show the highest amount of the highest isospecific active sites ((IS₃-sites) and only a few amount of aspecific active sites (AS-sites).

Moreover, TEA cocatalyst produced a few more of the second highest isospecific active sites (IS₂-sites) and semi-isospecific active sites (IS₁-sites) than DEAC cocatalyst. Another most interesting and important evidence is that the TREF elution peak from PP chains made by IS₃-sites with DEAC cocatalyst usually situates at 115~116°C, which is about 5°C higher than the peak at 110~111°C for TREF elution peak from PP chains made by IS₃-sites with TEA cocatalyst. This evidence indicates that the isospecificity of the IS₃-sites activated by DEAC is even much higher than that of the IS₃-sites activated by TEA. As shown in Figure 5, there is a slight decrease the amount of AS-sites and a slight increase of both IS₂-sites and IS₁-sites with the increase of Al/Ti molar ratio for the WG TiCl₃ catalyst with TEA as cocatalyst. For the same WG-TiCl₃/TEA catalyst/cocatalyst system, a slight increase of the amount of AS-sites, IS₂-sites and IS₁-sites with the increase of polymerization temperature can be observed. As for the WG-TiCl₃/DEAC catalyst/cocatalyst system, there is a slight increase of the amount of both AS-sites and IS₂-sites with the increase of either Al/Ti molar ratio or polymerization temperature. Based on our previous understanding on the isospecific roles of Al-alkyl cocatalysts for donor-free MgCl₂/TiCl₄ catalyst systems [20, 22] and isospecific active sites models proposed in the literature [5-10] as well as the results presented in this work, a mechanism regarding the isospecific role of Al-alkyl cocatalyst was proposed in Scheme 1 for the origin of isospecific sites on donor-free TiCl₃ Ziegler-Natta catalyst systems.



Scheme 1. Plausible isospecific nature of active sites on the surface of donor-free TiCl₃-based Ziegler-Natta catalyst depending on the type of Al-alkyl (either TEA or DEAC) used as cocatalyst. (Et): ethyl ligand, (□): coordination vacancy.

According to the mechanism shown in Scheme 1, there exist a lot of surface titanium chloride species with two coordination vacancies situated at edges and defects of surface on the WG and DG TiCl₃ catalysts. After a contact with Al-alkyl cocatalyst TEA or DEAC, these surface titanium chloride species with two coordination vacancies can be alkylated resulting into the formation of active sites, Sites-A. Sites-A are aspecific active sites (AS-sites), which can only produce atactic PP. Subsequently, Sites-A can further coordinate with Al-alkyl cocatalyst in the polymerization media. If TEA is used as cocatalyst, the coordination of Sites-A with TEA results in the formation of Ti-Al bimetallic complex Sites-B. In the case of using DEAC as

cocatalyst, the coordination of Sites-A with DEAC results in the formation of Sites-C. Both Sites-B and Sites-C belong to the highest isospecific sites (IS₃-sites), which can produce highly isotactic PP. However, these Ti-Al bimetallic complexing reactions are usually reversible depending on the cocatalyst [9, 12]. Natta et al. demonstrated that the stability of the Ti-Al bimetallic complex bridging through two chlorine atoms was higher than that bridging through one chlorine atom and one ethyl group [40]. It means Sites-C formed from Sites-A and DEAC should be much more stable than Sites-B from Sites-A and TEA. As the higher stability of the Ti-Al bimetallic complex usually means the higher isospecificity of active sites on the catalyst [41-43]. This can rationalize why the cocatalyst play so important role in the isospecific nature of active sites on TiCl₃ catalysts, which is a long-standing experimental fact that the stereoregularity of PP obtained from conventional heterogeneous donor-free Ziegler-Natta catalysts could be significantly enhanced solely through replacing TEA with DEAC as cocatalyst [42-44]. So far, from the detailed experimental results including the catalyst preparation procedure, propylene polymerization followed by systematic characterization of PPs using GPC, ¹³C NMR, and TREF, a basic understanding concerning the isospecific nature of active sites of donor-free TiCl₃ catalyst had been obtained. Further experimental work of a series studies on the surface physico-chemical nature of these catalyst systems used in the present study is still in progress through application of XRD, XPS, ²⁷Al solid state NMR etc. methods, in which more profound insights into the isospecific nature of active sites especially with respect to the existing states of active titanium species, Al-alkyl cocatalyst on the TiCl₃ catalyst surface will surely be achieved progressively soon.

In this study, a detailed experimental approaches to the real nature of isospecific sites on the first generation TiCl₃ Ziegler-Natta catalyst in terms of various catalyst preparation and polymerization conditions including WG and DG ball-milling, type of Al-alkyl cocatalysts TEA and DEAC, pretreatment of catalyst by cocatalyst before polymerization, Al/Ti molar ratio and polymerization temperature had been performed followed by the systematic characterization of PPs by GPC, NMR and TREF methods. The polymerization activity, MW of PP, isospecificity and isospecificity distribution of the active sites of TiCl₃ catalysts are mostly related to the types of Al-alkyl cocatalysts. The catalyst systems using TEA usually show much higher polymerization activity but much lower average isotacticity, MW of PPs and isospecificity of active sites in comparison with those using DEAC. TREF analyses show that TiCl₃/TEA catalyst systems contain dominantly aspecific active sites accompanied with certain amount of the highest isospecific sites and a few poorly isospecific sites. On the other hand, TiCl₃/DEAC catalyst systems contain dominantly the highest isospecific sites together with a few aspecific active sites and poorly isospecific sites. A plausible mechanism (Scheme 1) regarding the formation of the highest isospecific active sites in terms of Ti-Al bimetallic complexing reactions with TEA and DEAC had been proposed. The catalyst preparation method in terms of either WG or DG was found to be the second most important factor in determining isospecific nature of active sites and polymerization activity. Other parameters did not show obvious effects on the isospecific nature of active sites and polymerization behavior. These basic and profound understandings with respect to stereospecific nature of active sites of the first generation donor-free Ziegler-Natta catalyst gave rise to a better basis for our further effort to clearly elucidate the nature of isospecific active sites and origin of isospecificity in heterogeneous Ziegler-Natta catalysis soon.

Acknowledgements. The authors thank Toho Catalyst Co. Ltd., Asahi Chemical Industry Co. Ltd., Japan Polypropylene Co. Ltd., and Tosoh Finechem Corp. for their support and donation to our laboratory.

References

- Ziegler K, (1955) *Angew. Chem.* 67: 426.
- Natta G, Pino P, Corradini P, Danusso F, Mantica E, Mazzanti G, Moraglio G, (1955) *J. Am. Chem. Soc.* 77: 1708.
- Moore Jr. EP, (1998) "The Rebirth of Polypropylene: Supported Catalysts", Hanser Publishers, Munich.
- Liu B, Matsuoka H, Terano M, (2001) *Macromol. Rapid Commun.* 22: 1.
- Rodriguez LAM, Van Looy HM, (1966) *J. Polym. Sci.: Part A-1* 4: 1971.
- Boor Jr. J, (1979) "Ziegler-Natta Catalysts and Polymerizations", Academic press, New York, Chapter 15: p. 403-405, and references therein.
- Kohara T, Shinoyama M, Doi Y and Keii T, (1979) *Makromol. Chem.* 180: 2139.
- Doi Y, (1982) *Makromol. Chem., Rapid Commun.* 3: 635.
- Xu J, Feng L, Yang S, (1997) *Macromolecules* 30: 2539.
- Busico V, Cipullo R, Monaco G, Talarico G, and Vacatello M, Chadwick JC, Segre AL, and Sudmeijer O, (1999) *Macromolecules* 32: 4173.
- Sacchi MC, Forlini F, Tritto I, Locatelli P, (1995) *Macromol. Chem. Phys.* 196: 2881.
- Sacchi MC, Tritto L, Locatelli P, (1991) *Prog. Polym. Sci.* 16: 331.
- Soga K, Park JR, Uchino H, Uozumi T, Shiono T, (1989) *Macromolecules* 22: 3824.
- Soga K, Shiono T, Doi Y, (1988) *Makromol. Chem.* 189: 1531.
- Busico V, Corradini P, Martino LD, Proto A, (1986) *Makromol. Chem.* 187: 1115.
- Matsuoka H, Liu B, Nakatani H, Terano M, (2001) *Macromol. Rapid Commun.* 22: 326.
- Liu B, Matsuoka H, Terano M, (2001) *Macromol. Symp.* 165: 3.
- Matsuoka H, Liu B, Nakatani H, Nishiyama I, Terano M, (2002) *Polym. Int.* 51: 781.
- Nitta T, Liu B, Nakatani H, Terano M, (2002) *J. Mol. Catal. A: Chem.* 180: 25.
- Liu B, Nitta T, Nakatani H, Terano M, (2002) *Macromol. Chem. Phys.* 203: 2412.
- Liu B, Nitta T, Nakatani H, Terano M, (2003) *Macromol. Chem. Phys.* 204: 395.
- Liu B, Nitta T, Nakatani H, Terano M, (2004) *Macromol. Symp.* 213: 7.
- Vesely K, Ambroz J, Mejzlík J, Spousta E, (1967) *J. Polym. Sci., Part C*, 16: pp. 417.
- Boor Jr. J, (1967) *Macromolecular reviews*, Interscience, New York, 2: pp. 115.
- Wilchinsky ZW, Looney RW, Tornqvist EGM, (1973) *Journal of Catalysis.* 28: 351.
- Natta G, Corradini P, Allegra G, (1961) *J. Polym. Sci.*, 51: 399.
- Tornqvist EGM, (1969) *Ann. N. Y. Acad. Sci.*, 155: 447.
- Tornqvist EGM, Richardson JT, Wilchinsky ZW, Looney RW, (1967) *J. catal.*, 8: 189.
- Vecchi E, Zannetti R, Luciani L, Barbè P, (1961) *Chim. Ind. (Milan)* 43: 741.
- Allegra G, (1962) *Nuovo Cimento, (X)* 23: 502.
- Corradini P, Allegra G, (1961) *Rend. Accad. Naz. Lincei* 30: 182.
- Roger S, Laurent D, Alain G, (1988) *Makromol. Chem.* 189: 549.
- Dusseault JJA, Hsu CC, (1993) *J Macromol. Sci. Rev. Macromol. Chem. Phys.* C33: 103.
- Caunt AD, (1963) in *Macromolecular Chemistry*, Paris, *J. Polym. Sci. C*, 4.
- Magat M, (1963) Ed. Interscience, New York, pp. 49.
- Kissin YV, (1985) *Isospecific Polymerization of Olefins with Heterogeneous Ziegler-Natta Catalysts*, Springer: New York.
- Yuan GG, Taylor TW, Choi KY, and Ray WH, (1982) *J. Appl. Polym. Sci.*, 27: 1691.
- Kissin YV, (2001) *J. Polym. Sci.: Part A: Polymer Chemistry*, 39: 1681.
- Yuan GG, Taylor TW, Choi KY, and Ray WH, (1982) *J. Appl. Polym. Sci.*, 27: 1691.
- Natta G, Mazzanti G, (1960) *Tetrahedron*, 8: 86.
- Natta G, (1959) *J. Polym. Sci.* 34: 21.
- Natta G, Pasquon I, Zambelli A, Gatti G, (1961) *J. Polym. Sci.* 51: 387.
- Danusso F, (1963) *J. Polym. Sci. Part C* 4: 1497.
- Kakugo M, Miyatake T, Naito Y, Mizunuma K, (1988) *Macromolecules*, 21, 314.